

**Datasheet**

Issued: August 22, 2019  
File Edition: V1.0.0



Figure 1. Buspro Energy Meter & Gateway

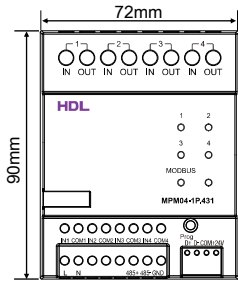

Figure 2. Dimensions - Front View

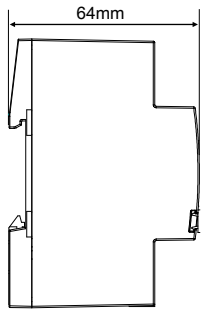

Figure 3. Dimensions - Side View

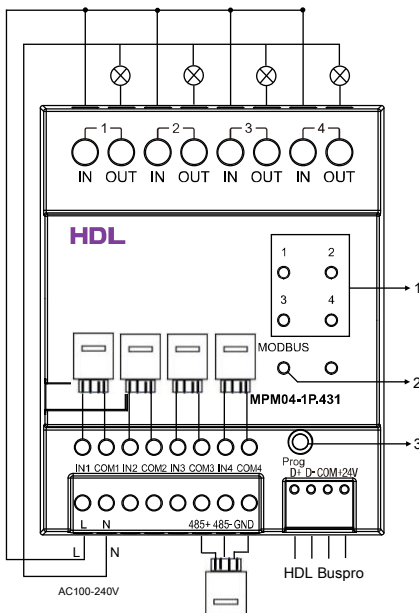

Figure 4. Wiring

## Overview

Buspro Energy Meter & Gateway (See Figure 1) is a management module that collects energy usage in hotel rooms. The Buspro Energy Meter & Gateway is compatible with Modbus and HDL Buspro devices. It can connect up to 6 Modbus devices to monitor the energy status of each bus device.

Its functions include:

- Compatible with Modbus and HDL Buspro devices
- Real-time monitoring of energy status of each bus
- Self-contained 4-channel single-phase power monitoring
- Supports 4-channel pulsed water, electricity and gas meter monitoring
- Comes with a power-down clock
- Save energy data locally
- Supports input voltage 110 V or 220 V
- As the host reads the relevant energy measurement device data on the Modbus: real-time voltage, real-time current, real-time power, etc., which is determined by the function of the third-party instrumentation device.
- The module's 4 single-phase energy monitoring channels support voltage (too low, too high) alarm, over current alarm, overload alarm.
- Correction time and record data
- The pulsed monitoring channels record water meters, electricity meters and gas meters
- Online update supported via HDL Buspro Setup Tool

## Components and Operation

Dimensions - See Figure 2 - 3

Wiring - See Figure 4

1. Status indicators of CH1-4 (single-phase energy monitoring channels)

When the channel indicator keeps on red, the device is working abnormally.

When the channel indicator flashes in red, the device is working properly.

When the channel indicator is off, the channel is connected to the load and the device is working properly.

2. Modbus status indicator

When the status indicator is off, the Bus interface is not enabled. When the indicator flashes in green, the Bus receives the data.

Programming button & indicator: The indicator will flash when the device is working properly. Keep pressing the button for 3s, the ID can be read and modified via HDL Buspro Setup Tool.

## Installation

Installation - See Figure 5 - 7

Step 1. Fix the DIN rail with screws.

Step 2. Buckle the bottom cap of the device on the edge of the DIN rail.

Step 3. Press the device on the DIN rail, slide it and fix it up until an appropriate position is adjusted.

## Important Notes

- HDL Buspro cable - CAT5E or dedicated HDL Buspro cable.
- HDL Buspro connection - Series connection (hand-in-hand recommended)
- Check connections - Re-tighten all connections after installation.

## Safety Precautions

- The installation and commissioning of the device must be carried out by HDL or the organization designated by HDL. For planning and construction of electric installations, the relevant guidelines, regulations and standards of the respective country are to be considered.
- HDL does not take responsibility for all the consequences caused by installation and wire connection that are not in accordance with this document.
- Please do not privately disassemble the device or change components, otherwise it may cause mechanical failure, electric shock, fire or body injury.
- Please resort to our customer service department or designated agencies for maintenance service. The warranty is not applicable for the product fault caused by private disassembly.
- It is not allowed to exceed the range.

## Package Contents

HDL-MPM04-1P.431\*1 / Buspro connector\*1 / Label\*5 / Datasheet\*1

## Technical Data

### Basic Parameters

Working voltage	24~30V DC
Working current	30mA/24V DC
Input voltage	AC100-240V (50/60Hz)
Electric energy monitoring channel	4 channels
Pulsed water, electricity and gas meter monitoring channel	4 channels
Monitoring channel current range	25mA~20A
Communication	HDL Buspro

### External Environment

Working temperature	-5°C~45°C
Working relative humidity	≤90%
Storage temperature	-20°C~60°C
Storage relative humidity	≤93%

### Specifications

Dimensions	72mm×90mm×64mm
Net weight	243g
Housing material	PA66
Installation	35mm DIN rail installation (See Figure 5 - 7)
Protection rating (Compliant with EN 60529)	IP20

### Name and Content of Hazardous Substances in Products

Components	Hazardous substances					
	Lead (Pb)	Mercury (Hg)	Cadmium (Cd)	Chromium VI (Cr (VI))	Poly-brominated biphenyls (PBB)	Poly-brominated diphenyl ethers (PBDE)
Plastic	o	o	o	o	o	o
Hardware	o	o	o	o	-	-
Screw	o	o	o	x	-	-
Solder	x	o	o	o	-	-
PCB	x	o	o	o	o	o
IC	o	o	o	o	x	x

The symbol “-” indicates that the hazardous substance is not contained.

The symbol "o" indicates that the content of the hazardous substances in all the homogeneous materials of the component is below the limit requirement specified in the Standard IEC62321-2015.

The symbol “x” indicates that the content of the hazardous substance in at least one of the homogeneous materials of the part exceeds the limit requirement specified in the Standard IEC62321-2015.

## HDL Buspro Cable Guide

HDL Buspro	HDL Buspro Cable	CAT5/CAT5E
DATA+	Yellow	Blue/Green
DATA-	White	Blue white/Green white
COM	Black	Brown white/Orange white
24V DC	Red	Brown/Orange



Figure 5

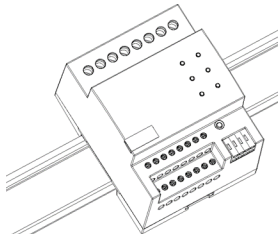

Figure 6

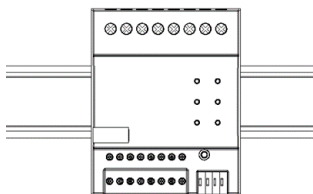

Figure 7

Figure 5 - 7. Installation

#### Technical support

E-mail: [hdltickets@hdlautomation.com](mailto:hdltickets@hdlautomation.com)

Website: <https://www.hdlautomation.com>

©Copyright by HDL Automation Co., Ltd. All rights reserved.  
Specifications subject to change without notice.